

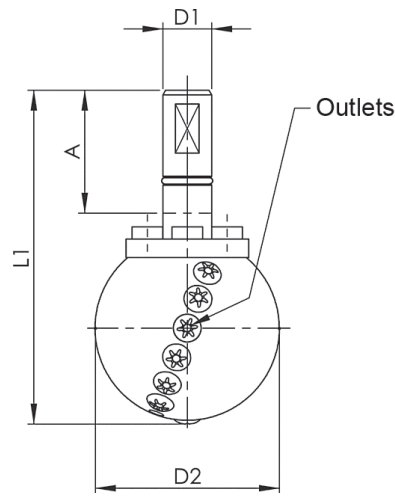

JERGENS WASHDOWN TOOL

Cleaning tool attachment for machine spindle, fits 16 mm Weldon holders. The cleaning range of the Jergens Cleaner is 360° and can be shaped through the number of opened outlets. The user selects which outlets to open which controls the pressure and direction of the jets. Moving and rotating the spindle under constant flow of coolant achieves an excellent and systematic cleaning of the machine interior. Through the optional installation of a pressure gauge, the status of the pump, filter and entire supply line can be checked.

- Outlets: 14
- Working Medium: Machine Coolant
- Repeatable, systematic and thorough cleaning of a machine interior
- No aerosol pollution harmful to the health of the machine operator
- Reduction of cleaning time
- Wash away chips and clean machine at scheduled intervals during long machining cycles or “lights out” machining periods when no operator is present.



Part Number	D1 (mm)	D2 (mm)	L1 (mm)	Insertion Depth A (mm)	Max RPM 1/min	Min Pressure psi (bar)	Max Pressure psi (bar)	Weight (g)
567196	16	60	110	40	100	72 (5)	1,740 (120)	331

