



2023

# Tooling Solutions

For Machining Aluminum  
Precision PCD and Solid Carbide



Precision - Quality - Flexibility

## Precision tools as standards and special solutions for machining Aluminum

The diversity of aluminum alloys with their special properties have a great influence on factors such as chip shape, surface, heat development, cutting force, etc.

The most common machining operations are covered by the wide-ranging standard catalog assortment for wrought and cast aluminum alloys as well as for non-ferrous metals and copper alloys.

Spiral drills	Deep hole drills	Reamers	End mills	Toric end mills	Ball nose end mills	Special end mills
Ø 0,5-25 mm	Ø 2-14 mm	Ø 0,5-32 mm	Ø 0,3-32 mm	Ø 0,2-32 mm	Ø 0,2-20 mm	Ø 0,2-32 mm

### Other dimensions on request

On request, we manufacture customized precision special tools made of solid carbide and PCD and offer the right solution for your special application.

Grinding, eroding or laser machining - the machining of the geometry is individually adapted depending on the design.

All tools are available with various shank designs and HSF technology and can also be adjusted for machining with minimum quantity lubrication.

### Special polishing process for tools with mirror-smooth surfaces

In order to meet market requirements, HAM has developed a hybrid, technologically highly complex solution for surface treatment - **Hybrid Surface Finishing (HSF)**, a treatment through which a reproducible and process-reliable cutting edge rounding of 4µm for aluminium is achieved with simultaneous polishing of all tool surfaces in the cutting area.

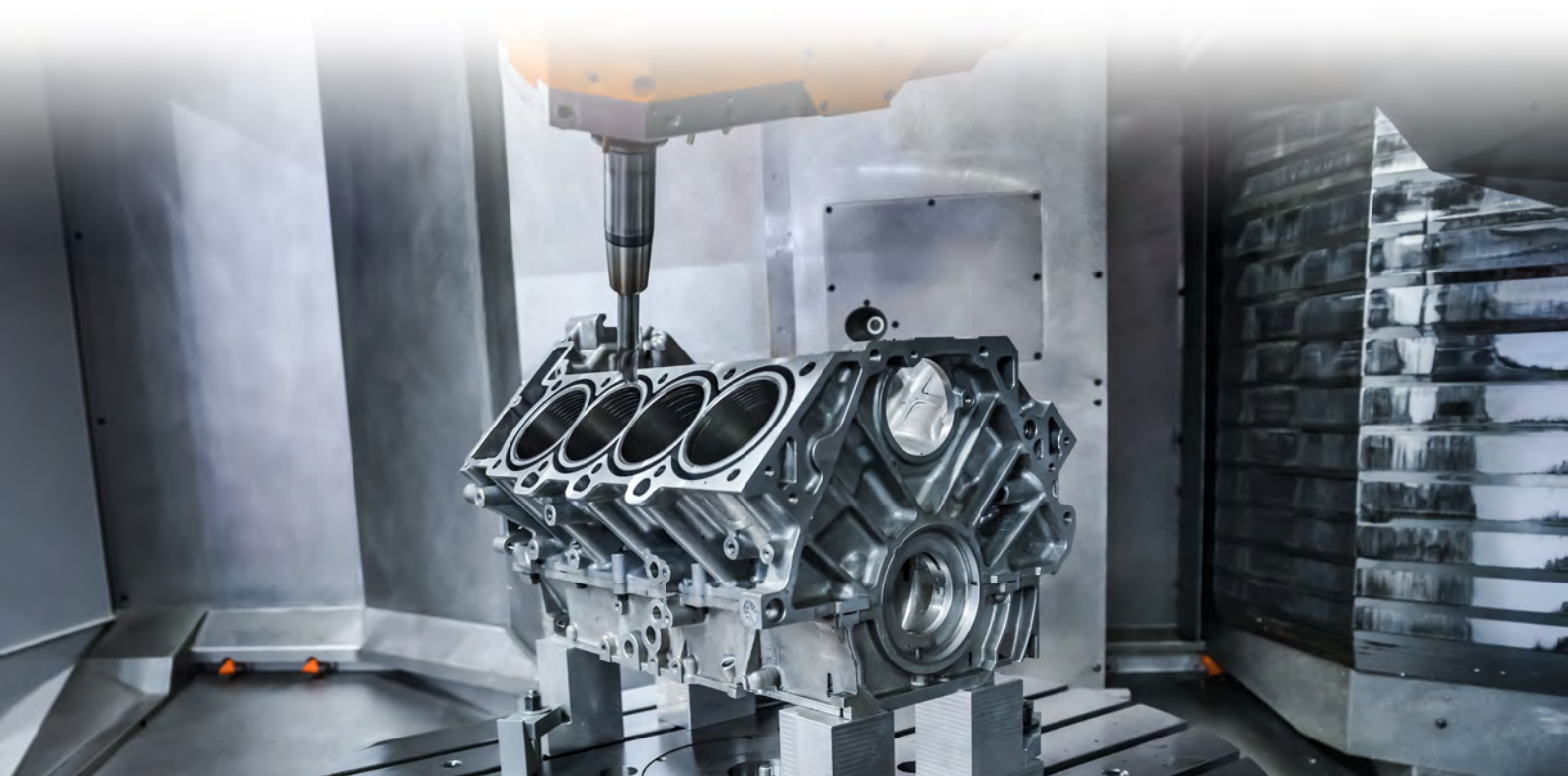

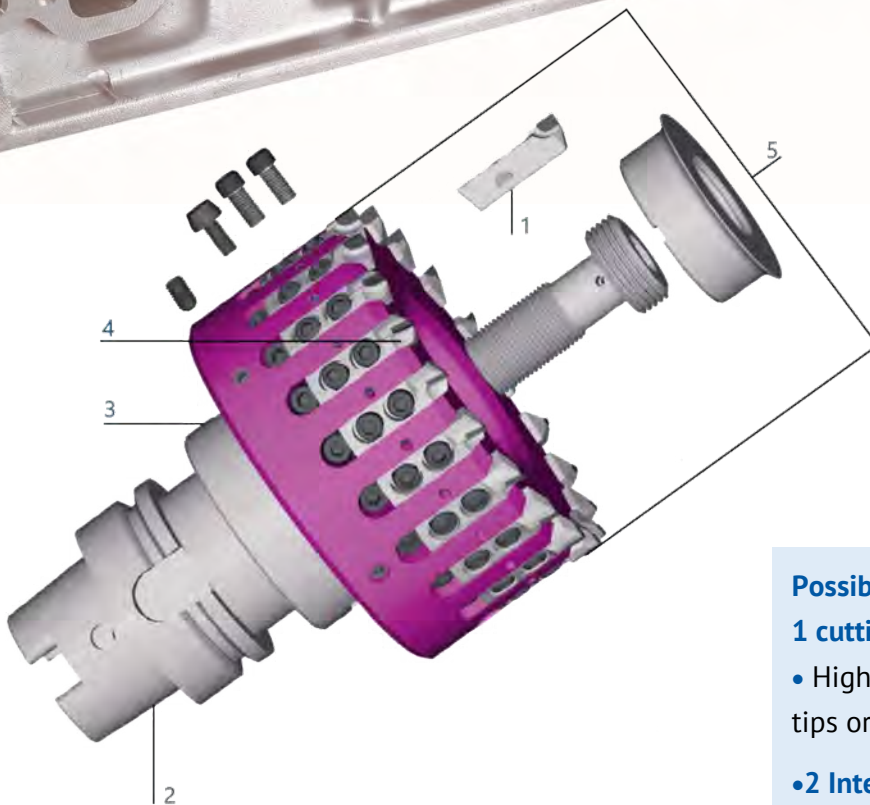
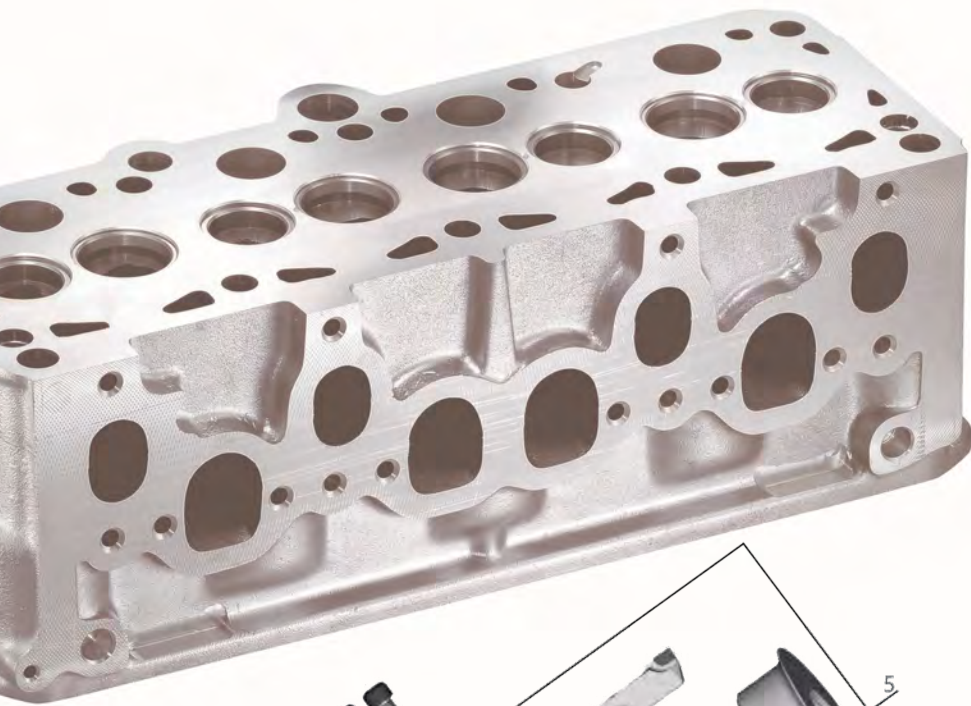

## Diamond Milling Cutter Systems

### Productivity at the maximum

With the wide variety of milling cutter systems, we offer you the highest possible productivity through maximum number of cutting edges. The exchangeable cutting inserts guarantee you the highest precision with optimum surface quality, which can also be easily adjusted by means of a lateral fine adjustment. Both the monobloc versions and the screwed plug-on head versions offer you significantly longer tool lives than conventional milling systems.

On request, we will support you from concept development to acceptance on the machine for special solutions of any kind, regardless of interfaces or face machining.

### Possible variants of the cutterhead systems

#### 1 cutting edge executions

- Highest surface quality through brazed PCD tips or replaceable indexable insert solutions

#### •2 Interfaces

- HSK 32–160
- SK 30–60
- BT 30 – 50
- ABS 32–80
- Modul 60
- ANSI CAT 40

#### 3 complete version

- Flexibility through modular plug-on heads or monobloc variants

#### •4 cooling

- Depending on the design, directly onto the cutting edge by means of internal cooling

#### 5 diameter range

- Ø 40 - 315 mm

Your partner in precision tool technology



**North American Importer & Distributor**

T. Friedl Enterprises (2000) Inc  
79 Milliken Blvd. Unit 4  
Toronto, Ontario, CA  
M1V 1V3

Tel: 416-321-0770  
Fax: 416-292-3254

Internet: [www.ham-tools.com](http://www.ham-tools.com) | [www.tfriedl.com](http://www.tfriedl.com)  
E-Mail: [HAMSALES@tfriedl.com](mailto:HAMSALES@tfriedl.com)



*Hartmetallwerkzeugfabrik  
Andreas Maier GmbH  
Stegwiesen 2  
D-88477 Schwendi-Hörsenhausen  
Telefon +49 7347 / 61-0  
Telefax +49 7347 / 61-142  
[www.ham-tools.com](http://www.ham-tools.com)*

